

Exploded View

产品编码(Product model):
 客户编码(Customer No):
 客户型号(Customer model):
 订单编码(Order Product Code):

22022516001725
 G0000340
 MOX430U-24HFN8-QRD0W(GA)
 62225-H6963916

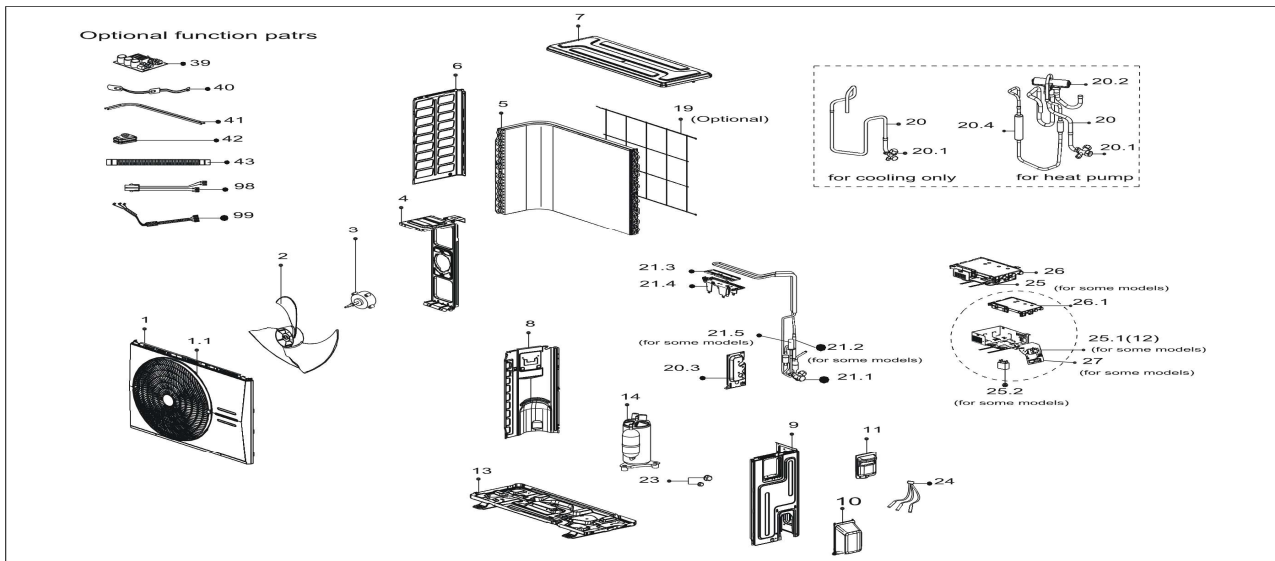
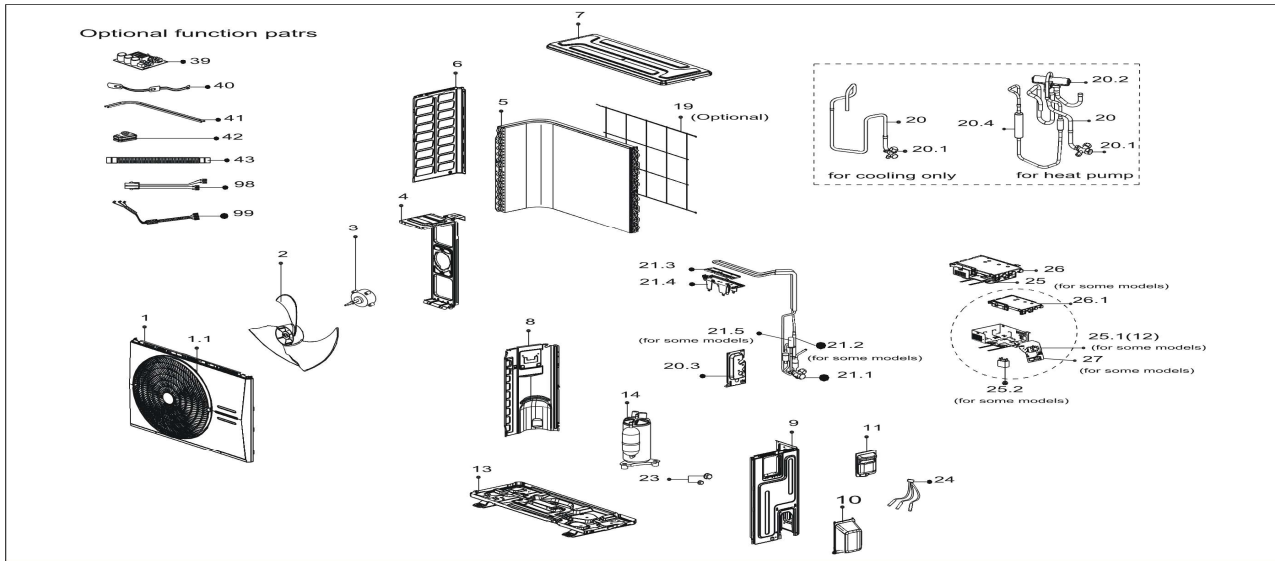

EX_ID	Spare Parts Code	Part Name(CN)	Part Name(EN)	Qty.	Remark2	Part Status	Drawing No	MIN_ORD ER_QTY	Long Term Material(Y or N)	High Rate of Replacemen t(Y or N)
1	12222000013248	前面板部件	Front panel	1		In Use	KFR-72W-X401.6A	1		
1.1	12122000026481	出风网罩	Air outlet grille	1		In Use	WX401.SL.1	1		
2	12100105000841	轴流风叶	Axial flow fan	1		In Use	ZL-535*133*12-3KFN	1		
3	11002015000366	无刷直流电机	Brushless DC Motor	1		In Use	ZKFN-80-8-3	0		
4	12222000012371	电机支架	Supporter of fan motor	1		In Use	KFR-72W-X401.3-1	1		
5	15822000009836	冷凝器部件	Condenser assembly	1		In Use	KFR-72W/BP3N8-X401.JC.ZL.1B	1		
6	12222000012929	左侧板	Left supporter	1		In Use	KFR-72W-X401.4-1A	1		
7	12222200005737	顶盖部件	Top cover assembly	1		In Use	KFR-72W-X401.7	1		
8	12222000013245	隔板部件	Partition board assembly	1		In Use	KFR-72W-X401.2	1		
9	12222000012930	右侧板部件	Right clapboard assembly	1		In Use	KFR-72W-X401.5A	1		
10	12122000007150	接水盘	Water collector	1		In Use	BA01.SL-2	1		
11	12122000031166	大把手部件	Big handle assembly	1		In Use	WX201.SL.1	1		
12	17400401000075	接线座(5位)UL认证	Terminal	1		In Use	JXZ-PT5H-A	1		
13	12222000013507	底座部件	Chassis Assembly	1		In Use	WX401.BJ.1B	1		
14	11103020006879	变频旋转式压缩机	DC Inverter Rotary Compressor	1		In Use	KTM240D43UKT	1		
20	15422000019694	四通阀部件	4-way valve assembly	1		In Use	EU-KFR70W/BP3N8-X401(RD0).ZL.1A	1		
20.1	15500204000502	低压阀	Gas valve	1		In Use	DYF-C16N2	1		
20.2	15500216000026	四通阀(R410A,线长450,VHR连接器)	4-way Valve	1		In Use	STF-02BN1(VHR)	1		
20.3	12222200005738	阀安装板	Valve plate	1		In Use	KFR-72W-X401-1	1		
20.4	15122000027161	消声器组件	Muffler subassembly	1		In Use	EU-KFR70W/BP3N8-X401(RD0).ZL.1.1(GT)	1		
20.7	15122000027116	消声器组件	Muffler subassembly	1		In Use	KFR-72W/BP3N8-X401.JC.ZL.2.1A(GT)	1		
21	15422000019272	高压阀部件	Liquid valve assembly	1		In Use	EU-KFR71W/BP3T1N8-X401(RD0).ZL.1	1		

21.1	15500208000286	高压阀	Liquid valve	1		In Use	GYF-C27N			
21.2	15500210004472	节流阀	Throttle valve	1		In Use	JLF(G)-042-N8-N6	1		
21.2	15500210001668	节流阀	Throttle valve	1		In Use	JLF(G)-042-N8-N6	1		
21.3	11203803001176	散热器	Radiator	1		In Use	SRQ155.2*37.9*5.3-AIQ80g-N	1		
21.4	12122000011478	U型铜管支撑	U-Typed Support with Copper Pipe	1		In Use	C01.DKH.SL-1	1		
21.5	15500213000176	电子膨胀阀	Electronic expansion valve body	1		In Use	DPF(T01)1.65C-35(L=900)	1		
23	15500406000003	铜螺母	Copper nut	1	A01=6.35mm(1/4in);B02=9.52mm(3/8in);C03=12.7mm(1/2in);D04=15.9mm(5/8in);E05=19mm(3/4in);F07=22mm(7/8in)	In Use	TLM-D04	0	N	N
23	15500406000010	铜螺母	Copper nut	1	A01=6.35mm(1/4in);B02=9.52mm(3/8in);C03=12.7mm(1/2in);D04=15.9mm(5/8in);E05=19mm(3/4in);F07=22mm(7/8in)	In Use	TLM-B02	0	N	N
24	11201011000188	组合传感器	Combination sensor	1		In Use	CGQ-ZH-GW/SW/PQ-L1100-XH-P900-3(CH)	1		
25	17222000031763	电控盒端子板组件	Terminal board subassembly	1		In Use	KFR-72W/BP3N8-X401.JD.TY.BDZ.DZ1.2-1B	1		
26	17222000033855	外销变频室外电控盒组件	Electronic control box subassembly	1		In Use	EU-KFR71W/BP3T1N8-X401(LMG+KTM240+RX24Tmini+6MBP30XSFO60+6892).JD.FW.WXWKB.DK1	1		
26.1	12122000008999	电控安装盒	Electronic installing box	1		In Use	KFR-26W/BP2N1-J181.D.13.DK1.1.1-1A	1		
99	17401203012697	压缩机连接线组	Compressor wire subassembly	1		In Use	PXQ-YSJ200RD/190BL/210BK-14#PA66	1		